

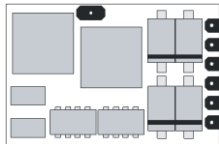

Doehler & Haass

# LOCOMOTIVE DECODER



**DHP160**

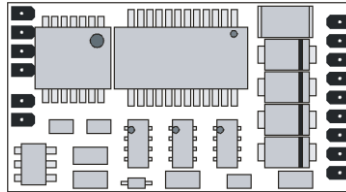

**DHP250**

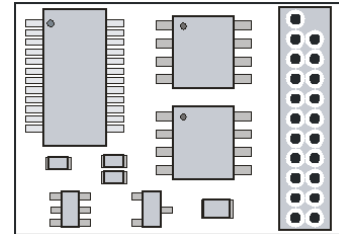

**DHP260**

## Loco Decoder DHP160

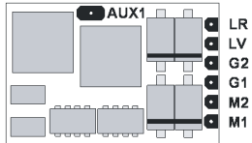

## Loco Decoder DHP250

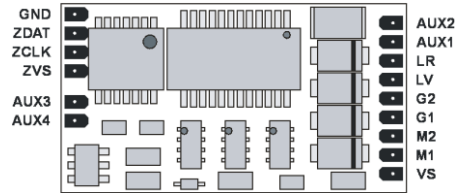

## Loco Decoder DHP260

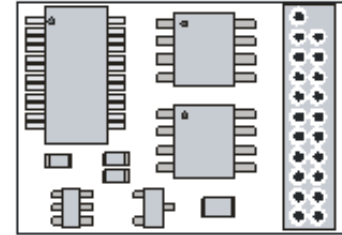

G1, G2	Track 1, 2
M1, M2	Motor 1, 2
LV	Front light
LR	Rear light
AUX1 ... AUX4	Additional functions 1 ... 4
VS	Supply voltage (+)

ZVS	SUSI supply voltage
ZCLK	SUSI clock
ZDAT	SUSI data
GND	SUSI ground

## Content

1	Introduction	4
2	Safety instructions	5
3	Warranty	5
4	Support and Help	5
5	Functions	6
6	Decoder-Installation	7
6.1	Preparation	7
6.2	Check after the insertion	7
6.3	Installation	8
7	Operating system SelecTRIX 1 (SX1)	11
7.1	Functions	11
7.2	Setup features	11
7.3	Operation	14
7.4	Explication of the signal-stopping section	14
8	Operating system DCC	15
8.1	Functions	15
8.2	Setup features	15
8.3	Operation	22
9	Operating system SelecTRIX 2 (SX2)	23
9.1	Functions	23
9.2	Setup features	23
9.3	Operation	30
	Supplement 1	31
	Supplement 2	33

	<b>DHP160</b>	<b>DHP250</b>	<b>DHP260</b>
<b>Specifications</b>			
Dimensions [mm]	14,2 x 9,2 x 2,0	23,3 x 12,9 x 2,7	22,2 x 15,7 x 5,7
Total load	1,0 A	1,5 A	2,0 A
Maximum motor current	1,0 A	1,5 A	2,0 A
Maximum operating voltage	25 V	25 V	25 V
Function outputs light: LV, LR	each 300 mA	each 300 mA	each 300 mA
Function output AUX1	300 mA	300 mA	300 mA
Function outputs AUX2, AUX3, AUX4	not available	je 1,0 A	je 1,0 A
SUSI interface	not available	available	available
<b>Connection options</b>			
Without connection wires	DHP160	DHP250	
With ribbon cable for interface per NEM651	DHP161		
With connecting cable for interface per NEM652		DHP252	
With connection wires	DHP163	DHP253	
21-pin connector for direct plug			DHP260

## 1 Introduction

The locomotive decoder DH05A and DH10A are compatible with the protocols of SelecTRIX Standard SX1 / SX2 as well as with NMRA-DCC-Standard. They can be controlled by every central control unit working with one of these data formats.

They can be used for normal direct current motors as well as for coreless motors.

**The operation on alternating current supplied layouts with switching impulse is not allowed. The impulse excitation will destroy the decoder.**

## **2 Safety instructions**

This product is not suitable for children under 14 years! It might be swallowed by children under 3 years! An improper use involves a risk of injury due to sharp edges and points.

## **3 Warranty**

The functioning of every decoder is fully tested before delivery. The warranty period is 2 years from the date of purchase. Should a failure occur during this period please contact the dealer where you purchased the decoder respectively directly the producer Doehler & Haass.

## **4 Support and Help**

In case you have any problems or questions, please contact us by E-Mail under the address

**[doehler-haass@t-online.de](mailto:doehler-haass@t-online.de)**

Normally you will get an answer within a few days.

## 5 Functions

- Operation can be controlled either by conventional DC command stations or by digital central units supporting the formats SelectRIX 1 and 2 or NMRA-DCC
- Automatically switchover from conventional DC to digital operation
- In case of digital operation the last programmed system will be activated (no automatically switchover!)
- SelectRIX 1 31 speed steps, 100 addresses
- SelectRIX 2 127 speed steps, 10.000 addresses, 16 additional functions
- DCC Short addresses (1-127), long addresses (0001-9999), with 14, 28, 126 speed steps
- Load compensation state of the art, that way an especially smooth regulation behavior
- Various regulation variants for an optimal adaptation to the motor
- 127 internal speed steps
- Block system operation by simple diodes (digital operating system)
- Light and function output AUX1 can be dimmed and activated analogically
- Function outputs AUX2, AUX3 and AUX4 (only if available) can activated analogically
- Shunting gear
- Electronic interchange ability of motor, lighting and track connections
- All function outputs freely programmable
- Thermal protection, insulation
- Reset function for DCC and SX2
- Decoder can be updated:  
The update can be executed on the incorporated decoder when the loco is standing on the track (no need to open the engine, the SW-Download can be downloaded from the Internet cost free)

## 6 Decoder-Installation

### 6.1 Preparation

Check if the locomotive is in perfect running order electrically and mechanically, prior to any mounting work. Defects and dirt must be eliminated first. Pay attention to the instructions of the locomotive producer. Only locomotives running smoothly in analogue mode, should be equipped with a digital decoder. New locomotives should be run in at least 30 minutes in each direction of travel.

Before you start, insulate the motor and all its terminals completely against track connections (chassis, collector slipper, etc.).

**Both motor connections must be disconnected from the ground!**

Further on, all condensers have to be removed, particularly those associated with the connections of light and motor.

Fix the decoder with a double sided adhesive tape.

### 6.2 Check after the insertion

The first test should be executed in the programming mode (e.g. by reading out the address). In case of an incorrect feedback (confirmation signal) to the central unit ("error"), please check again the correct assignment of the connections respectively if the motor is really disconnected from the chassis electrically.

## 6.3 Installation

There are two variants to connect the decoder:

- 1 In case your locomotive is equipped with an interface (NEM 651), you should take the decoder **DHP161**. They have already the appropriate connections for this plug. Shorten the ribbon cable up to approximately 5 mm and remove the rest of the insulation. The decoder can be inserted into the interface without any problem now.
- 2 In case your locomotive is equipped with an interface (NEM 652), you should take the decoder **DHP252**. They have already the appropriate connections for this plug. The decoder can be inserted into the interface without any problem now.
- 3 In case your locomotive is equipped with a 21-pin interface, you should take the decoder **DHP260**. They have already the appropriate connections for this plug. The decoder can be inserted into the interface without any problem now.
- 4 If the locomotive is not equipped with an interface jack, the decoder must be wired up individually. For this purpose you should use decoder with flexible wires (**DHP163** respectively **DHP253**).
- 5 The decoder **DHP160** respectively **DHP250** should be used by experienced model railroaders only as the connection wires must be soldered directly onto the decoder.



Connect the decoder wires accordingly to the following diagram:

red wire	with the right track wire (G1)
black wire	with the left track wire (G2)
orange wire	with the motor wire, which was connected to the right track (M1)
gray wire	with the motor wire, which was connected to the left track (M2)
white wire	with the front light (LV)
yellow wire	with the rear light (LR)
green wire	function output AUX1 (only DHP <b>252</b> and DHP <b>253</b> )
violet wire	function output AUX2 (only DHP <b>253</b> )
blue wire	supply voltage up to 25 volts (+VS) (only DHP <b>252</b> and DHP <b>253</b> )

In addition for SUSI interface (only if available):

red wire	SUSI supply voltage (ZVS)
blue wire	SUSI clock (ZCLK)
gray wire	SUSI data (ZDAT)
black wire	SUSI ground (GND)

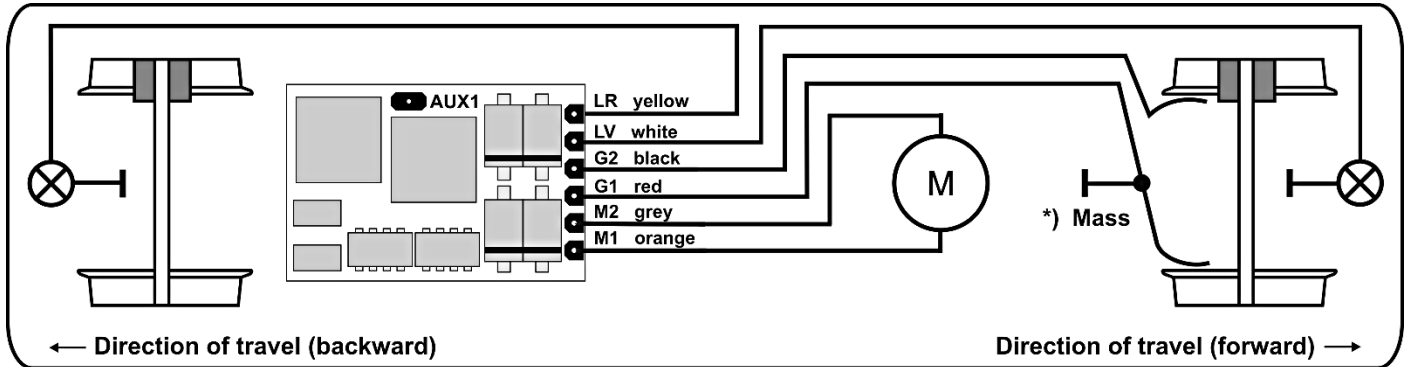

\*) The mass can either be connected to wheel 1 or 2, depending on the producer

#### Function outputs:

The function outputs AUX1, AUX2, AUX3 and AUX4 (only if available) are on the edge of the decoder and must be connected to the consumers with individual wires (see Illustration, page 2).

#### Notice:

In case of an incorrect wiring of motor, lighting and track, there is no need to solder off the wires as the assignment can be interchanged electronically by programming (see adjustment options of the respective operating system).

## 7 Operating system SelectRIX 1 (SX1)

### 7.1 Functions

Speed steps	31
Speed steps (internal)	127
Front light / rear light	
Additional functions	1, 2 or 4
Additional channel available (Loco address + 1) with 8 additional functions	

### 7.2 Setup features

All locomotive parameters can be varied by programming freely at any time. Please, take the information concerning the programming from the instructions of your programming device.

#### Basic setups

Loco address	01 ... 111	(01)
Velocity	1 ... 7	(5)
Acceleration / Deceleration	1 ... 7	(4)
Impulse width (duration)	1 ... 4	(2)
Signal-stopping section	1 / 2 parts	(1)

### Extended setups

Interchange of connections	(V)	0 ... 7	(4)
Activation of AFB and additional channel	(A)	1 ... 6	(1)
Motor regulation variant	(I)	1 ... 4	(3)

AFB ("Automatische Fahr-/Bremssteuerung") = Automatically acceleration / deceleration control

Interchange of connections		0 ... 7	(4)
Interchange motor connections	1		
Interchange light connections	2		
Interchange track connections	4		

### Activation of AFB and additional channel

Function	With AFB	Without AFB
Without additional channel	1	2
With ZK*) without function mapping	3	4
With ZK*) with function mapping	5	6

\*) the additional channel ZK ("Zusatzkanal") has always the address: Loco address + 1

Motor regulation variant		1 ... 4	
User defined by par056 ff.	1		
Hard	2		
Soft	3		
Very soft	4		

Reading out the extended characteristic values is executed by the entry of the character sequence

**00-111**

and a subsequently push on the programming key.

Writing of the extended characteristic values is executed by the entry of the character sequence

**00=VAI**

and a subsequently push on the programming key.

**Notice:**

Coreless motors should be operated with regulation variant 4 and pulse width 1. Damages due to incorrect adjustments are excluded from the warranty.

**Caution!**

Reading out and entering extended characteristic values overwrites the default-values of the decoder. In case you have varied the extended characteristic values, the default characteristic values of the decoder must be entered anew.

### **7.3 Operation**

Put the locomotive on the programming track and read out the programming parameters of the decoder. The default value should be 01-542. Program the desired locomotive address and start running the locomotive keeping the other parameter values. After the first check you can vary the parameters of the engine freely according to your requirements.

In case your programming device indicates "error", please check again the correct wiring of the locomotive and pay attention to the wiring instructions of the programming track. Never put such a locomotive into operation!

### **7.4 Explication of the signal-stopping section**

One-part signal-stopping section:

In front of the signal one track section is controlled by a diode. The decoder must be programmed on one-part stopping section (-). The locomotive will be braked to a halt.

Two-part signal-stopping section:

In front of the signal there are two track sections. The first one is controlled by a diode and the locomotive will be braked down to internal speed step 3 in this section. The second one is without supply and the locomotive will stop just in front of the signal. The decoder must be programmed on two-part stopping section (=).

## 8 Operating system DCC

### 8.1 Functions

Short addresses	1 – 127
Long addresses	0001 – 9999
Speed steps	14, 28, 126
Speed steps (internal)	127
Front light / rear light (can be dimmed)	
Additional function AUX1 (can be dimmed)	
Additional functions AUX2, AUX3, AUX4	(not DHP160)
Operation with break diodes	yes
Operation with break generators	yes
Consist mode	yes
Full NMRA conform	yes
Programming on the main (POM)	yes

### 8.2 Setup features

The characteristics of a locomotive operated in the DCC-operating mode can be varied by programming the configuration variables (CV) freely at any time. The programming procedure is described in the instructions of your programming device.

#### Notice:

In case the speed steps programmed on the decoder differ from those of the control device, malfunctions may occur. Please pay attention to the respective information concerning your digital system.

List of supported CV:

CV	Name	Definition	Range	Standard																											
01	Short address		0 – 127	3																											
02	Starting voltage	Reserved																													
03	Acceleration time	The value corresponds to the time in seconds from start to maximum speed	0 – 255	3																											
04	Deceleration time	The value corresponds to the time in seconds from maximum speed to stop	0 – 255	3																											
05	Maximum speed	See supplement 2	0 – 127	92																											
07	Version number	Version number																													
08	Manufacturer identification	97 = Doehler & Haass Decoder Reset by "8"																													
09	Motor frequency	0 = 32 kHz, 2 = low frequency	0, 2	0																											
13	Analog mode F1 – F8	<table border="1"> <thead> <tr> <th>Bit</th> <th>Function</th> <th>Value</th> </tr> </thead> <tbody> <tr> <td>0</td> <td>F1</td> <td>1</td> </tr> <tr> <td>1</td> <td>F2</td> <td>2</td> </tr> <tr> <td>2</td> <td>F3</td> <td>4</td> </tr> <tr> <td>3</td> <td>F4</td> <td>8</td> </tr> <tr> <td>4</td> <td>F5</td> <td>16</td> </tr> <tr> <td>5</td> <td>F6</td> <td>32</td> </tr> <tr> <td>6</td> <td>F7</td> <td>64</td> </tr> <tr> <td>7</td> <td>F8</td> <td>128</td> </tr> </tbody> </table>	Bit	Function	Value	0	F1	1	1	F2	2	2	F3	4	3	F4	8	4	F5	16	5	F6	32	6	F7	64	7	F8	128	0 – 255	1
Bit	Function	Value																													
0	F1	1																													
1	F2	2																													
2	F3	4																													
3	F4	8																													
4	F5	16																													
5	F6	32																													
6	F7	64																													
7	F8	128																													



14	Analog mode FL, F9 – F12	<table border="1"> <thead> <tr> <th>Bit</th> <th>Function</th> <th>Value</th> </tr> </thead> <tbody> <tr> <td>0</td> <td>FL (f)</td> <td>1</td> </tr> <tr> <td>1</td> <td>FL (r)</td> <td>2</td> </tr> <tr> <td>2</td> <td>F9</td> <td>4</td> </tr> <tr> <td>3</td> <td>F10</td> <td>8</td> </tr> <tr> <td>4</td> <td>F11</td> <td>16</td> </tr> <tr> <td>5</td> <td>F12</td> <td>32</td> </tr> </tbody> </table>	Bit	Function	Value	0	FL (f)	1	1	FL (r)	2	2	F9	4	3	F10	8	4	F11	16	5	F12	32	0 – 63	3						
Bit	Function	Value																													
0	FL (f)	1																													
1	FL (r)	2																													
2	F9	4																													
3	F10	8																													
4	F11	16																													
5	F12	32																													
17 18	Long address	<p>CV17 contains the most significant byte, CV18 contains the least significant byte,</p> <p>Only if activated by CV29</p>	0 – 255	192 0																											
19	Consist address	<p>Several compound locos run under this address.</p> <p>0 = deactivated</p> <p>Value + <b>128</b> = inverse direction</p>	0 – 127	0																											
21	Consist mode F1 – F8	<table border="1"> <thead> <tr> <th>Bit</th> <th>Function</th> <th>Value</th> </tr> </thead> <tbody> <tr> <td>0</td> <td>F1</td> <td>1</td> </tr> <tr> <td>1</td> <td>F2</td> <td>2</td> </tr> <tr> <td>2</td> <td>F3</td> <td>4</td> </tr> <tr> <td>3</td> <td>F4</td> <td>8</td> </tr> <tr> <td>4</td> <td>F5</td> <td>16</td> </tr> <tr> <td>5</td> <td>F6</td> <td>32</td> </tr> <tr> <td>6</td> <td>F7</td> <td>64</td> </tr> <tr> <td>7</td> <td>F8</td> <td>128</td> </tr> </tbody> </table>	Bit	Function	Value	0	F1	1	1	F2	2	2	F3	4	3	F4	8	4	F5	16	5	F6	32	6	F7	64	7	F8	128	0 – 255	0
Bit	Function	Value																													
0	F1	1																													
1	F2	2																													
2	F3	4																													
3	F4	8																													
4	F5	16																													
5	F6	32																													
6	F7	64																													
7	F8	128																													

22	Consist mode FL, F9 – F12	0 FL (f) 1 1 FL (r) 2 2 F9 4 3 F10 8 4 F11 16 5 F12 32	0 – 63	0
29	Configuration register	Various adjustments Bit Function 0 Inverse direction 1 14 ↔ 28/126 speed steps 2 Analog operation permitted 3 --- 4 --- 5 Long address by CV17/18 6 --- 7 ---	0 – 255	6
33	Function mapping F0(f)	See supplement 1	0 – 255	1
34	Function mapping F0(r)	See supplement 1	0 – 255	2
35	Function mapping F1(f+r)	See supplement 1 If CV35 is written, CV47 will be set to the same value	0 – 255	4
36	Function mapping F2(f+r)	See supplement 1 If CV36 is written, CV64 will be set to the same value	0 – 255	8
37	Function mapping F3	See supplement 1	0 – 255	16
38	Function mapping F4	See supplement 1	0 – 255	128
39	Function mapping F5	See supplement 1	0 – 255	32

40	Function mapping F6	See supplement 1	0 – 255	0												
41	Function mapping F7	See supplement 1	0 – 255	0												
42	Function mapping F8	See supplement 1	0 – 255	64												
43	Function mapping F9	See supplement 1	0 – 255	0												
44	Function mapping F10	See supplement 1	0 – 255	0												
45	Function mapping F11	See supplement 1	0 – 255	0												
46	Function mapping F12	See supplement 1	0 – 255	0												
47	Function mapping F1(r)	See supplement 1 In case CV47 should have another value as CV35, you have to set CV35 first and then CV47	0 – 255	4												
48	Characteristic diagram	Response curve 0 = linear 7 = logarithmic See supplement 2	0 – 7	5												
49	Impulse with	0 = 1 ms 1 = 2 ms 2 = 4 ms 3 = 8 ms	0 – 3	1												
50	Regulation variant	0 = user defined by CV56 ff. 1 = Hard 2 = Soft 3 = Very Soft	0 – 3	2												
51	Interchange of connections	<table border="0"> <thead> <tr> <th>Bit</th> <th>Function</th> <th>Value</th> </tr> </thead> <tbody> <tr> <td>0</td> <td>Motor connections</td> <td>1</td> </tr> <tr> <td>1</td> <td>Light connections</td> <td>2</td> </tr> <tr> <td>2</td> <td>Track connections</td> <td>4</td> </tr> </tbody> </table>	Bit	Function	Value	0	Motor connections	1	1	Light connections	2	2	Track connections	4	0 – 7	0
Bit	Function	Value														
0	Motor connections	1														
1	Light connections	2														
2	Track connections	4														

52	Dimming light "normal"	0 = off ... 31 = full brightness	0 – 31	31
53	Dimming light "alternative"	0 = off ... 31 = full brightness	0 – 31	15
54	Dimming AUX1	0 = off ... 31 = full brightness	0 – 31	31
55	Dimming AUX2	Reserved		
56	Motor proportional controller	Only if activated by CV50 = 0	0 – 7	3
57	Motor integral controller	Only if activated by CV50 = 0	0 – 3	3
58	Motor measurement period	Only if activated by CV50 = 0	0 – 3	1
59	Motor impulse width	Only if activated by CV50 = 0	0 – 7	3
60	Signal-stopping section	1 or 2	0, 1	0
61	Shunting gear speed		0 – 127	63
62	Shunting gear deceleration	See CV03	0 – 255	1
63	Start delay speed step 1		0 – 250	0
64	Function mapping F2(r)	See supplement 1 In case CV64 should have another value as CV36, you have to set CV36 first and then CV64	0 – 255	8
105	User identifier 1		0 – 255	0
106	User identifier 2		0 – 255	0
113	Preclusion for LV	Bit 0 = F1 to bit 7 = F8	0 – 255	0
114	Preclusion for LR	See CV113	0 – 255	0
115	Preclusion for AUX1	See CV113	0 – 255	0
116	Preclusion for AUX2	See CV113	0 – 255	0
117	Timer for clear AUX1	Each 100 ms, 0 = deactivated	0 – 250	0
118	Timer for clear AUX2	Each 100 ms, 0 = deactivated	0 – 250	0
119	Timer for clear AUX3	Each 100 ms, 0 = deactivated	0 – 250	0
120	Timer for clear AUX4	Each 100 ms, 0 = deactivated	0 – 250	0

All configuration variables except for CV01, CV17 and CV18 (= locomotive addresses) can be accessed during operation on your layout (POM / programming on the main).

### 8.3 Operation

Put the locomotive on the programming track and read out the short locomotive address of the decoder (CV 01). The default value should be 3. Program the desired locomotive address and start running the locomotive keeping the other adjustment values. After the first check you can vary the parameters of the engine freely according to your requirements.

In case your programming device indicates "error", please check again the correct wiring of the locomotive and pay attention to the wiring instructions of the programming track. Never put such a locomotive into operation!

#### Notice:

Block section operation in the DC current operating mode is not possible with the factory settings. In case you want this option, you must set CV29 bit 2 to "1".

## **9 Operating system SelecTRIX 2 (SX2)**

### **9.1 Functions**

Speed steps	127
Speed steps (internal)	127
Front light / rear light (can be dimmed)	
Additional function AUX1 (can be dimmed)	
Additional functions AUX2, AUX3, AUX4 (not DHP160)	
Operation with break diodes	yes
Programming on the main (POM)	yes

### **9.2 Setup features**

The characteristics of a locomotive operated in the SX2-operating mode can be varied by programming the parameters (par) freely at any time. The parameter-programming procedure is described in the instructions of your programming device.

List of supported parameters:

par	Name	Definition	Range	Standard
001	Loco address unit position		0 – 99	1
002	Loco address hundred position		0 – 99	10
003	Loco address for SX1	If > 111 deactivated	0 – 255	112
004	Additional channel 1 for SX1	Functions F1 – F8	0 – 255	1
005	Additional channel 2 for SX1	Functions F9 – F16	0 – 255	0
006	Loco address output	Activated = 1	0, 1	1
007	Effectiveness additional channels	0 = relative: Additional 1 = par003 + par004 Additional 2 = par003 + par005 1 = absolute	0, 1	0
008	Consist address unit position	Reserved		
009	Consist address hundred position	Reserved		
011	Acceleration time	The value corresponds to the time in seconds from start to maximum speed	0 – 255	3
012	Deceleration time	See par011	0 – 255	3
013	Maximum speed	See supplement 2	0 – 127	92
014	Starting voltage	Reserved		
016	Start delay speed step 1	Each 0,1 sec Delay between receive of speed step 1 and start for the SUSI interface	0 – 250	0
018	Shunting gear speed	See supplement 2	0 – 127	63



019	Shunting gear deceleration	See par011	0 – 255	1																											
021	Signal-stopping section	1 or 2	0, 1	0																											
022	Consist mode F1 – F8	Reserved																													
023	Consist mode FL, F9 – F12	Reserved																													
024	Preclusion for LV	Bit 0 = F1 to bit 7 = F8	0 – 255	0																											
025	Preclusion for LR	See par024	0 – 255	0																											
026	Preclusion for AUX1	See par024	0 – 255	0																											
027	Preclusion for AUX2	See par024	0 – 255	0																											
028	Analog mode F1 – F8	<table border="1"> <thead> <tr> <th>Bit</th> <th>Function</th> <th>Value</th> </tr> </thead> <tbody> <tr> <td>0</td> <td>F1</td> <td>1</td> </tr> <tr> <td>1</td> <td>F2</td> <td>2</td> </tr> <tr> <td>2</td> <td>F3</td> <td>4</td> </tr> <tr> <td>3</td> <td>F4</td> <td>8</td> </tr> <tr> <td>4</td> <td>F5</td> <td>16</td> </tr> <tr> <td>5</td> <td>F6</td> <td>32</td> </tr> <tr> <td>6</td> <td>F7</td> <td>64</td> </tr> <tr> <td>7</td> <td>F8</td> <td>128</td> </tr> </tbody> </table>	Bit	Function	Value	0	F1	1	1	F2	2	2	F3	4	3	F4	8	4	F5	16	5	F6	32	6	F7	64	7	F8	128	0 – 255	1
Bit	Function	Value																													
0	F1	1																													
1	F2	2																													
2	F3	4																													
3	F4	8																													
4	F5	16																													
5	F6	32																													
6	F7	64																													
7	F8	128																													
029	Analog mode FL, F9 – F12	<table border="1"> <thead> <tr> <th>Bit</th> <th>Function</th> <th>Value</th> </tr> </thead> <tbody> <tr> <td>0</td> <td>FL (f)</td> <td>1</td> </tr> <tr> <td>1</td> <td>FL (r)</td> <td>2</td> </tr> <tr> <td>2</td> <td>F9</td> <td>4</td> </tr> <tr> <td>3</td> <td>F10</td> <td>8</td> </tr> <tr> <td>4</td> <td>F11</td> <td>16</td> </tr> <tr> <td>5</td> <td>F12</td> <td>32</td> </tr> </tbody> </table>	Bit	Function	Value	0	FL (f)	1	1	FL (r)	2	2	F9	4	3	F10	8	4	F11	16	5	F12	32	0 – 63	3						
Bit	Function	Value																													
0	FL (f)	1																													
1	FL (r)	2																													
2	F9	4																													
3	F10	8																													
4	F11	16																													
5	F12	32																													
031	Interchange of track connections	0 = normal, 1 = inversed	0, 1	0																											
032	Interchange of motor connections	0 = normal, 1 = inversed	0, 1	0																											
033	Interchange of light connections	0 = normal, 1 = inversed	0, 1	0																											

041	Operating system	Occurs during the programming automatically: <table border="1"> <thead> <tr> <th>Bit</th> <th>System</th> <th>Value</th> </tr> </thead> <tbody> <tr> <td>0</td> <td>SX1</td> <td>1</td> </tr> <tr> <td>1</td> <td>DCC</td> <td>2</td> </tr> <tr> <td>2</td> <td>SX2</td> <td>4</td> </tr> </tbody> </table>	Bit	System	Value	0	SX1	1	1	DCC	2	2	SX2	4	1, 2, 4	2
Bit	System	Value														
0	SX1	1														
1	DCC	2														
2	SX2	4														
051	Characteristic diagram	Response curve 0 = linear 7 = logarithmic See supplement 2	0 – 7	5												
052	Regulation variant	0 = user defined by par056 ff. 1 = Hard 2 = Soft 3 = Very Soft	0 – 3	2												
053	Impulse width	0 = 1 ms 1 = 2 ms 2 = 4 ms 3 = 8 ms	0 – 3	1												
054	Motor frequency	0 = 32 kHz, 2 = low frequency	0, 2	0												
056	Motor proportional controller	Only if activated by par052 = 0	0 – 7	3												
057	Motor integral controller	Only if activated by par052 = 0	0 – 3	3												
058	Motor measurement period	Only if activated by par052 = 0	0 – 3	1												
059	Motor impulse width	Only if activated by par052 = 0	0 – 7	3												
061	Function mapping F0(f)	See supplement 1	0 – 255	1												
062	Function mapping F0(r)	See supplement 1	0 – 255	2												

063	Function mapping F1(f+r)	See supplement 1 If par063 is written, par075 will be set to the same value	0 – 255	4
064	Function mapping F2(f+r)	See supplement 1 If par064 is written, par085 will be set to the same value	0 – 255	8
065	Function mapping F3	See supplement 1	0 – 255	16
066	Function mapping F4	See supplement 1	0 – 255	128
067	Function mapping F5	See supplement 1	0 – 255	32
068	Function mapping F6	See supplement 1	0 – 255	0
069	Function mapping F7	See supplement 1	0 – 255	0
070	Function mapping F8	See supplement 1	0 – 255	64
071	Function mapping F9	See supplement 1	0 – 255	0
072	Function mapping F10	See supplement 1	0 – 255	0
073	Function mapping F11	See supplement 1	0 – 255	0
074	Function mapping F12	See supplement 1	0 – 255	0
075	Function mapping F1(r)	See supplement 1 In case par075 should have another value as par063, you have to set par063 first and then par075	0 – 255	4
076	Timer for clear AUX1	Each 100 ms, 0 = deactivated	0 – 250	0
077	Timer for clear AUX2	Each 100 ms, 0 = deactivated	0 – 250	0
078	Timer for clear AUX3	Each 100 ms, 0 = deactivated	0 – 250	0
079	Timer for clear AUX4	Each 100 ms, 0 = deactivated	0 – 250	0
081	Dimming light "normal"	0 = off ... 31 = full brightness	0 – 31	31
082	Dimming light "alternative"	0 = off ... 31 = full brightness	0 – 31	15

083	Dimming AUX1	0 = off ... 31 = full brightness	0 – 31	31
084	Dimming AUX2	Reserved		
085	Function mapping F2(r)	See supplement 1 In case par085 should have another value as par064, you have to set par064 first and then par085	0 – 255	8
098	User identifier 1		0 – 255	0
099	User identifier 2		0 – 255	0
101	Manufacturer identifier	Read only: 97 = Doehler & Haass		
102	Decoder identifier	Read only: DHP160 = 16 DHP250 = 25 DHP260 = 26		
103	Version number	Read only		
104	Date	Read only		
105	Revision number	Read only		

All parameters except for par001 and par002 (= locomotive address) can be accessed during operation on your layout (POM / programming on the main).

### **9.3 Operation**

Put the locomotive on the programming track and read out the locomotive address of the decoder (par001+par002). The default value should be 1001. Program the desired locomotive address and start running the locomotive keeping the other parameter values. After the first check you can vary the parameters of the engine freely according to your requirements. In case your programming device indicates "error", please check again the correct wiring of the locomotive and pay attention to the wiring instructions of the programming track. Never put such a locomotive into operation!

## Supplement 1      Explanation for function mapping

If you want to activate a function enter the value to the corresponding output according to the following table. In case you want to activate several different functions by one and the same output you must add up their specific values.

Output's values:

	RG	ABL	AUX4	AUX3	AUX2	AUX1	LR	LV
Value	128	64	32	16	8	4	2	1

RG = Shunting gear    ABL = dimmed headlights

Example:            F4 should activate the shunting gear and switch on the outputs LV and LR:  
LV=1, LR=2, RG=128: so you must enter the value 131 in CV38 | par066.

Notice:            AUX4, AUX3 and AUX2 are not available in the decoder DHP160.

Timer function    (CV 117 - 120, par076 - 079)

Value = 0            The timer is switched off (continuous operation)

Value = 1...250    The timer is activated, the correspondent output will be disconnected after the set time of: entered value x 0,1 sec.

Preclusion (CV113 - 116, par024 - 027)

This function gives you the option to deactivate a function associated to an output partly (e.g. drivers cab light in front dark), though this output is switched on (e.g. LV by function F0).

Example: A typical situation where to apply this function is the push-pull operation. The front lighting pointing at the wagons must be switched off, but the other lights must be reversed in the direction of travel (white ↔ red).

- F0 switches on the light (white or red in dependency of the direction of travel)
- F2 switches off the front light
- F3 switches off the rear light

CV	par	Function	RG	ABL	AUX4	AUX3	AUX2	AUX1	LR	LV
33	061	F0(f)					x			x
34	062	F0(r)						x	x	

CV	par	Function	F8	F7	F6	F5	F4	F3	F2	F1
113	024	LV off							x	
114	025	LR off						x		
115	026	AUX1 off							x	
116	027	AUX2 off						x		

LV Front light white  
 AUX1 Front light red

LR Rear light white  
 AUX2 Rear light red



## Supplement 2

## Characteristic diagrams

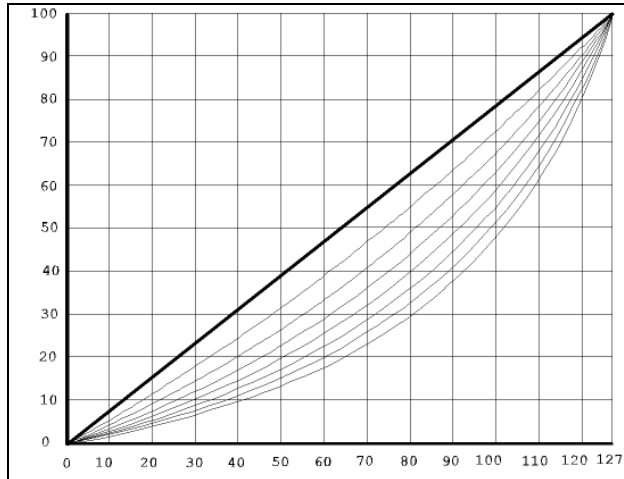

Speed step characteristics \*)

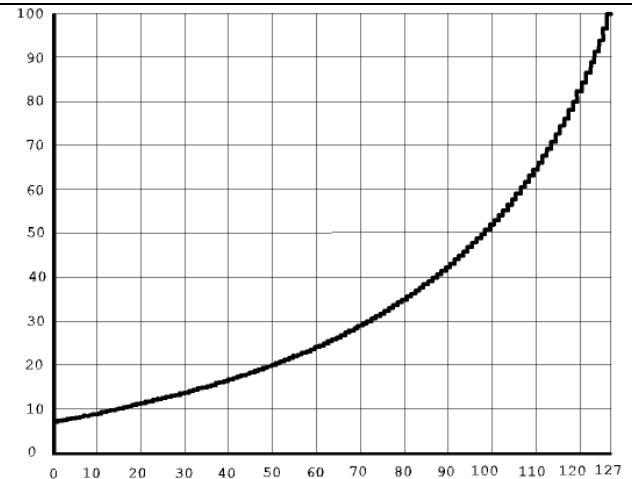

Maximum speed characteristic

Characteristic speed step diagram:

Linear                    0  
Logarithmic            7

\*) The curve 5 of the speed step characteristics corresponds with the DHL loco decoder series.





Never throw this product in the normal household waste at the end of its lifetime.  
Please, always use the waste disposal plant of your municipality.



Not suitable for children under 36 month because of the danger of swallowing the product and of injuries due to sharp-edged parts.

Nicht geeignet für Kinder unter 3 Jahren wegen der Gefahr des Verschluckens sowie der Verletzung durch scharfkantige Teile!

Ne convient pas aux enfants en dessous de 36 mois.

Company stamp

DOEHLER & HAASS GmbH  
Eichelhäherstrasse 54  
D-81249 München  
Tel. +49 (0)89 8641487  
[www.doehler-haass.de](http://www.doehler-haass.de)

© A. Haass  
Modifications and errors excepted

Version 03/2012